

Digital Undercounter ecostore HP Refrigerated Counter - 4 Door (R290) with cooling unit right

ITEM # _____

MODEL # _____

NAME # _____

SIS # _____

AIA # _____

710421 (EJ4HDAAAA)

 4-door Refrigerated
 Counter, -2+10°C, AISI 304
 (R290), with right cooling
 unit

Short Form Specification

Item No. _____

AISI 304 stainless steel panels, AISI 430 bottom panel, galvanized back panel. Worktop thickness 50mm. N. 4 full doors. Built-in refrigeration unit. Operating temperature: -2+10°C. R290 gas in refrigeration circuit. Supplied with 1 grid for each door compartment

Main Features

- Digital control panel allowing the easy and precise setting and control of the internal temperature.
- Operating temperature can be adjusted from -2 to +10 °C to suit different food storage requirements.
- Complies with main international certification bodies and is CE marked.
- Possibility to install on socklet.
- Kit 1/2 drawers available as accessory.
- Completely automatic defrosting and automatic evaporation of defrost water by hot gas.
- Forced air cooling system guaranteeing great uniformity of the temperature in the counter and excellent conservation of the food quality.
- Kit 1/3 drawers available as accessory.
- Connectivity ready for real time access to connected appliances from remote and data monitoring (requires optional accessory).
- Easy serviceability thanks to the intuitive control panel with access via app.
- Integrated RS485 port to facilitate connection to a remote computer and integrated HACCP systems.

Construction

- Built-in compressor to suit operating conditions.
- CFC and HCFC free.
- Legs in 304 AISI stainless steel (150 mm high, adjustable in height), with plastic interior.
- Internal and external doors, front and side panels and 50mm thick removable worktop in 304 AISI stainless steel.
- Back panel in galvanized steel.
- The door self-closes when opened less than at a 90° angle and is equipped with a door seal to guarantee perfect closure.
- High standards of hygiene and ease of cleaning are guaranteed by the rounded internal corners of the cabinet and easily removable runners and grids.

Included Accessories

- 4 of Kit 1/1 grey rilsan grid and 2 PNC 881109 side runners for refrigerated counters

Optional Accessories

- 1/1GN grey rilsan grid for refrigerated counters PNC 881107
- 2 side runners for 1/1 GN ecostore refrigerated counters PNC 881108
- Kit 1/1 grey rilsan grid and 2 side runners for refrigerated counters PNC 881109
- 1/1 GN plastic container, H=65 mm PNC 881110
- 1/1 GN plastic container, H=100 mm PNC 881111
- 1/1 GN plastic container, H=150 mm PNC 881112
- 2x½ drawer kit for refrigerated counters - h650mm PNC 881176

APPROVAL: _____

- 3x1/3 drawer kit for refrigerated counters - h650mm (only for refrigerated counters) PNC 881177
- 1/3 and 2/3 bottle drawer kit for refrigerated counters - h650mm (only for refrigerated counters) PNC 881178
- Kit 5 wheels, H=100 mm (3 with brakes) for 4 compartment refrigerated counters PNC 881192
- Kit 5 wheels, H=150 mm (2 with brakes) for 4 compartment refrigerated counters PNC 881194
- Lock for refrigerator/freezer counters with 4 compartments - h650mm (can be used in kit for Marine conversion) PNC 881247
- Kit 4 (45mm) spacers for wheels for refrigerator/freezer counters PNC 881277

Front

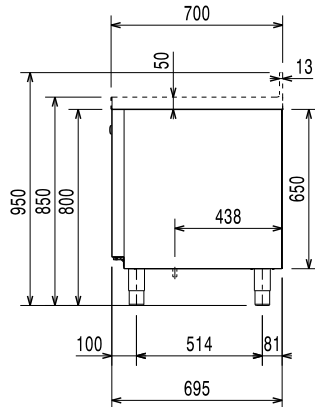

Side

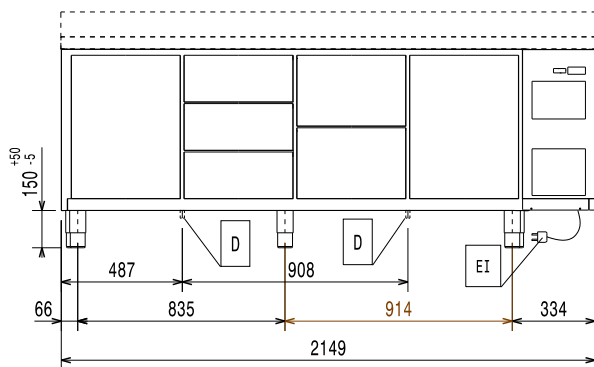

EI = Electrical inlet (power)

Top

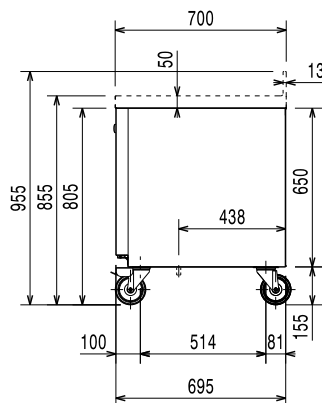

Electric

Supply voltage:	710421 (EJ4HDAAAA)	220-240 V/1 ph/50 Hz
Electrical power max.:		0.27 kW

Key Information:

Gross capacity:	
Net Volume:	327.2 lt
N° of doors:	
External dimensions, Width:	2153 mm
External dimensions, Depth:	700 mm
External dimensions, Height:	850 mm
Internal Dimensions, Width:	1706 mm
Internal Dimensions, Depth:	560 mm
Internal Dimensions, Height:	510 mm
Net weight:	134 kg
Shipping volume:	1.79 m ³
Depth with doors open:	1310 mm

Refrigeration Data

Control type:	Digital
Compressor power:	1/4 hp
Min/Max internal humidity:	40/85
Operating temperature min.:	-2 °C
Operating temperature max.:	10 °C
Operating mode:	Ventilated

ISO Certificates

ISO Standards:	ISO 9001; ISO 14001; ISO 45001; ISO 50001
----------------	---

Sustainability

Energy Class (EU Reg. 2015/1094):	B
Yearly and daily energy consumption (EU Reg. 2015/1094):	810kWh/year - 2kWh/24h
Climate class (EU Reg. 2015/1094):	Heavy Duty (5)
Energy Efficiency Index-EEL (EU Reg. 2015/1094):	30,85
Refrigerant type:	R290
GWP Index:	3
Refrigeration power:	395 W
Refrigerant weight:	65 g

EU energy labelling from 1st July 2016

The European energy labelling scheme for professional refrigerators and freezers is based on requirements setting Minimum Energy Performance standards for commercial refrigeration cabinets sold within the EU.

These requirements are designed to drive energy efficiency and environmentally friendly approach for professionals. The European energy labelling scheme will apply to all manufacturers and importers who sell and market products within the EU and it is mandatory across Europe. Important: all products which consume energy above the minimum level will not be able to be sold within the EU from 1 July 2016.

SI 2020 No. 1528.

Important: all products which consume energy above the minimum level will not be able to be sold within the EU from 1 July 2016.

